

# WS Exacta Series

Hydraulic sandwich diaphragm pumps with spring return mechanism

Standards



**ATEX**  
COMPLIANCE



**seko**

innovation > technology > future

# Hydraulic sandwich diaphragm pumps with spring return mechanism

Simplicity, reliability and easy installation are the most evident features of this line. The new WS series lies the technical innovation of a double diaphragm sandwich with a spring return operating mechanism.

- Stroke adjustment from 0 to 100% running or at rest. Adjustment locking device
- Electric motors in accordance with European Standards, multi-voltage and multi-frequency, 230-400V/3 50-60Hz, IP55, insulation class F with over-temperature B
- Working temperature  
-20 +80 °C for stainless steel pump head  
-10 +50 °C for plastic pump head

Options: single-phase, flameproof or special type

## Hydraulic sandwich diaphragm pump head

Joining the advantages of volumetric pumps with the sealless nature of diaphragms, hydraulic diaphragm pumps offer the solution to many dosing needs, when the pumping conditions and the fluids are hazardous or difficult.

The principle of the double diaphragm sandwich type offers several advantages:

- Double barrier between the pumped and the hydraulic fluids.
- The hydraulic fluid could be chosen to be compatible with the pumped medium.

## [EFD] Diaphragm Early Failure Detector

Under normal operating conditions, there is no pressure between the two diaphragms. If one of the two diaphragms leaks, an over-pressure is detected. The detection can be visual on side of remote via pressure switch.

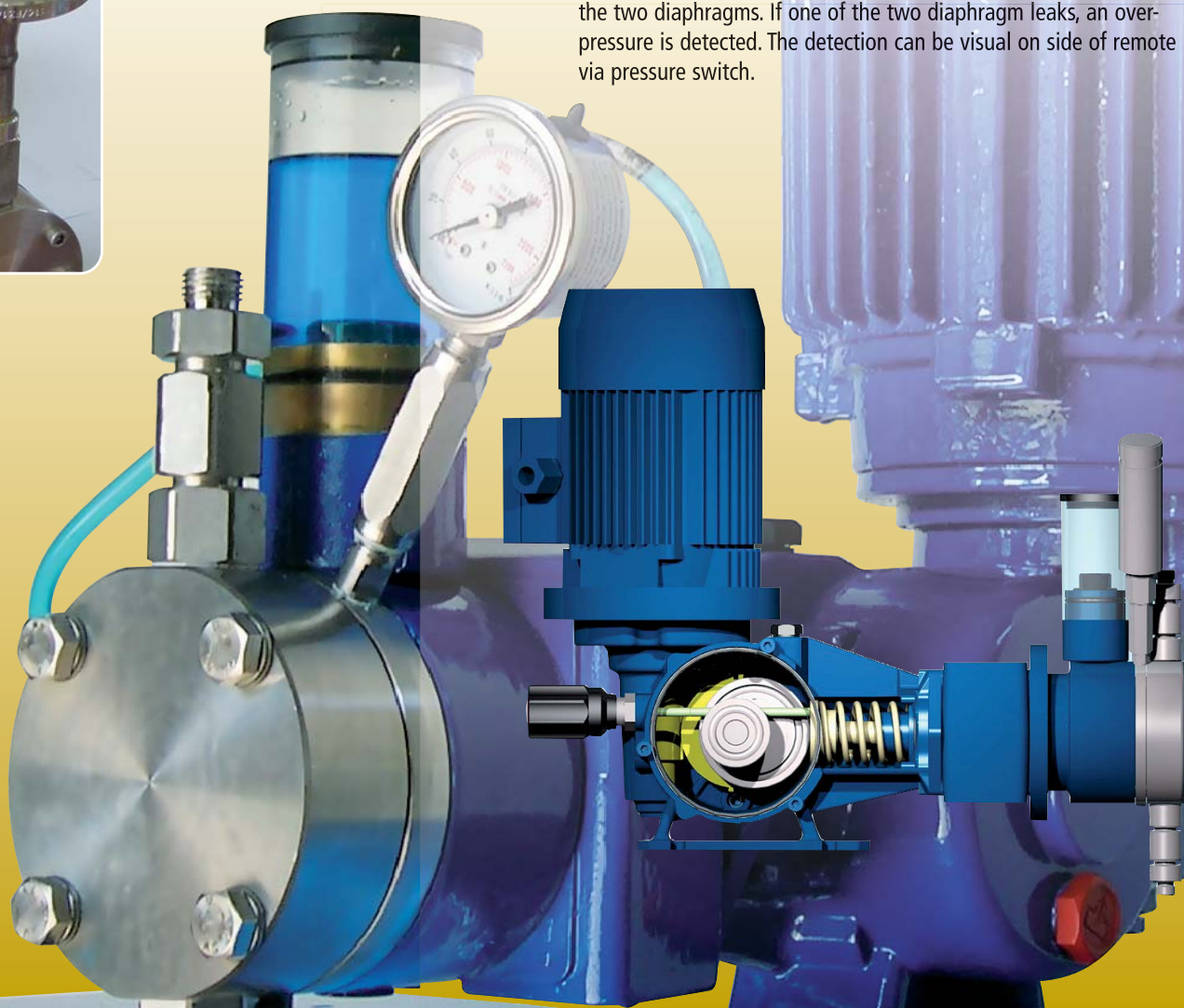

## The flow rate of the pump can be adjusted by:

- Manually with grip handle and graded vernier
- Electric servomotor with a 4-20mA signal and manual emergency adjuster
- Inverter, by regulating the speed of the motor, keeping the manual adjustment on the stroke length
- Pneumatic servomotor, especially for classified areas



### Electric servomotor

It's used when the pump's flow rate has to be automatically adjusted by analysis instruments such as PLC or DCS.

- Power Supply 115/230V - single phase - 50 Hz - IP65
- Manual emergency adjuster
- Regulation signal 4-20mA with reply signal

## WS1 Series

- Aluminium gearbox, compact and rugged
- Flow rate from 0,7 to 111 lt/h, max pressure 60 barg
- Stainless steel and plastic pump head
- Single or double ball valves
- PTFE diaphragm
- Standard connections as BBPF: on request flanged AISI, DIN, UNI

## WS2 Series

- Aluminium gearbox, compact and rugged
- Flow rate from 1,5 to 500 lt/h, max pressure 80 barg
- Stainless steel and plastic pump head
- Single or double balls valves
- PTFE diaphragm
- Standard connections as BBPF: on request flanged AISI, DIN, UNI

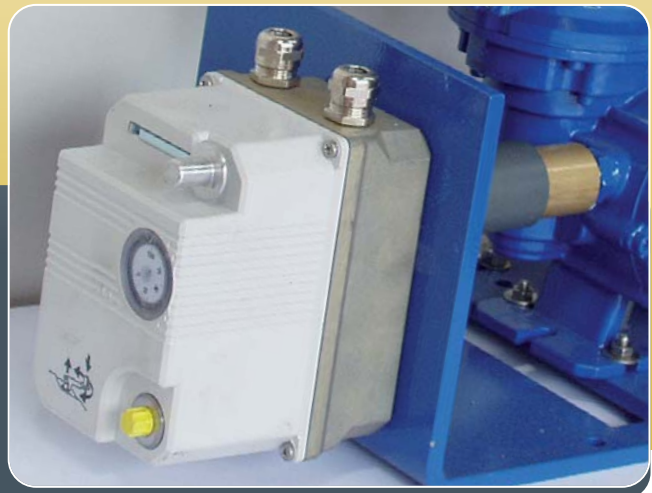

## Accessories

**Pressure safety valves** are installed to prevent dangerous situations in case of unexpected overpressure that can damage the pump and the pipes. Metering pumps can reach high pressure in one stroke, therefore they should be protected by possible clogging of the pipe caused, for instance, by accidental closure of valve. Hydraulic sandwich diaphragm pumps are protected with a limiting pressure valve built-in in the hydraulic circuit, the pitting should be protected by in-line pressure safety valve. On request PSV may be supplied with PED certificate.



**Pulsation dampers:** The reciprocating movement of the piston generates pulsations: during each stroke the liquid contained in the suction and discharge lines is accelerated from zero to the maximum speed and then decelerated to zero again. Pulsation dampers are the accessories suggested to reduce high and not permissible pressure fluctuations or to obtain a linearity of the flow.



**Back pressure valves:** To allow the correct operation of a pump and to prevent the flow-through (siphoning) of the process liquid, the discharge pressure should be greater than the suction pressure; when this condition is not respected then a backpressure valve can be the solution.



**Calibration pots:** The calibration pot installed on the suction line gives the possibility to check the actual flow rate of a metering pump in the real operating conditions. The capacity of the calibration pot should be as to permit a measurement during 30 or 60 seconds approx; the calibration pot should be installed in vertical position near the pump and should be fitted with check valve to simplify the use.



# WS1 Exacta Series

## Hydraulic sandwich diaphragm metering pumps

### Technical Features

Flow Rate	from 0,7 to 111 lt/h (0,2 to 29,3 gph)	
Pressure Max.	<b>SS 316L Version</b>	60 bar (870 psi)
	<b>PP Version</b>	10 bar (145 psi)
Stroke rate	58 • 78 • 116 stokes/minutes	
Piston Ø	from 6 to 47 mm	
Motor Powers	Standard 0,18 kW (IP55)	
Stroke Length	10 mm	

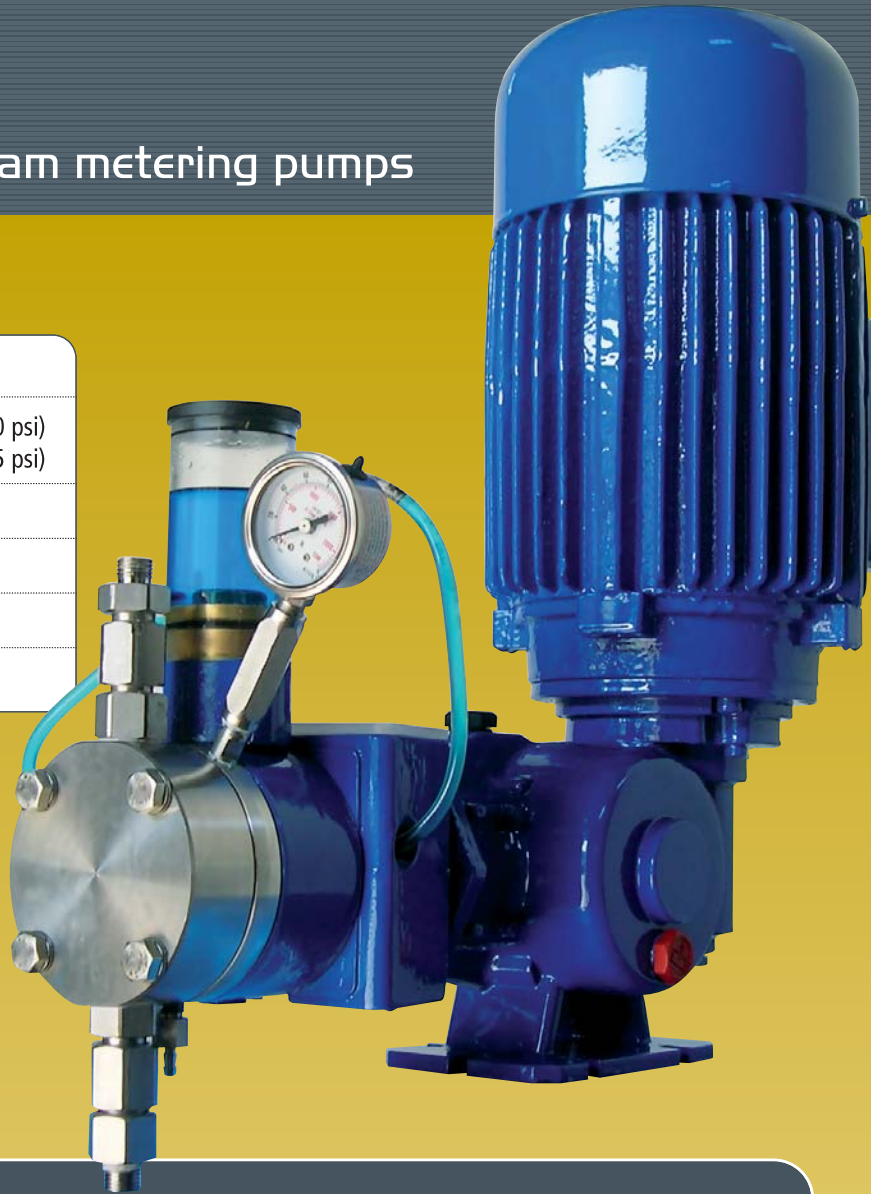
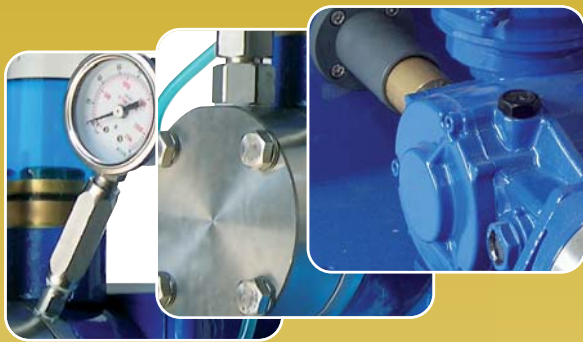

### WS1 Exacta Series

Model	Piston Ø	Stroke Length	50 Hz				60 Hz			Max. Pressure				Electric Motor	Suc/Dis. Connc.	
			Strokes /min.	Max. Flow Rate		Strokes /min.	Max. Flow Rate		SS 316L		PP		kW		SS 316L	PP
				lt/h	gph		lt/h	gph	bar	p.s.i.	bar	p.s.i.				
W S1 F 006 A	6	10	58	0,7	0,2	70	0,84	0,2	60	870	10	145	0,18	1/4" M	3/8" M	
W S1 F 006 B			78	1,0	0,3	94	0,9	0,2								
W S1 F 006 C			116	1,5	0,4	139	1,8	0,5								
W S1 F 012 A	12	10	58	3,0	0,8	70	3,6	1,0	60	870	10	145	0,18	1/4" M	3/8" M	
W S1 F 012 B			78	5,0	1,3	94	6	1,6								
W S1 F 012 C			116	6,0	1,6	139	7,2	1,9								
W S1 F 020 A	20	10	58	10,0	2,6	70	12	3,2	60	870	10	145	0,18	1/4" M	3/8" M	
W S1 F 020 B			78	12,5	3,3	94	15	4,0								
W S1 F 020 C			116	19,0	5,0	139	22,8	6,0								
W S1 F 028 A	28	10	58	18,0	4,8	70	21,6	5,7	40	580	10	145	0,18	1/4" M	3/8" M	
W S1 F 028 B			78	25,0	6,6	94	30	7,9								
W S1 F 028 C			116	36,0	9,5	139	43,2	11,4								
W S1 F 047 A	47	10	58	56,0	14,8	70	67,2	17,8	14	203	10	145	0,18	1/4" F	3/8" F	
W S1 F 047 B			78	75,0	19,8	94	90	23,8								
W S1 F 047 C			116	111,0	29,4	139	133,2	35,2								

Piston Ø [mm]	Conne. [BSP]	SS 316L Dimension [mm]						
		A	B	C	D	E	F	m
6	1/4" M (DV)	104	104	245	Height depends on motor type	Ø89	96	30°
12	1/4" M (DV)	101,5	101,5	227		Ø89	96	30°
20	1/4" M (DV)	109	109	228		Ø99	97	30°
28	1/4" M (SV)	83,5	83,5	238,5		Ø99	92	30°
47	1/4" F (SV)	100	105	266		Ø129	111,5	39°

Piston Ø [mm]	Conne. [BSP]	PP Dimension [mm]						
		A	B	C	D	E	F	m
6	3/8" M (DV)	104	104	245	Height depends on motor type	Ø89	96	30°
12	3/8" M (DV)	101,5	101,5	227		Ø89	96	30°
20	3/8" M (DV)	109	109	228		Ø99	97	30°
28	3/8" M (DV)	83,5	83,5	238,5		Ø99	92	30°
47	1/2" F (SV)	100	105	266		Ø129	111,5	39°

SV - Single check valves

DV - Double check valves

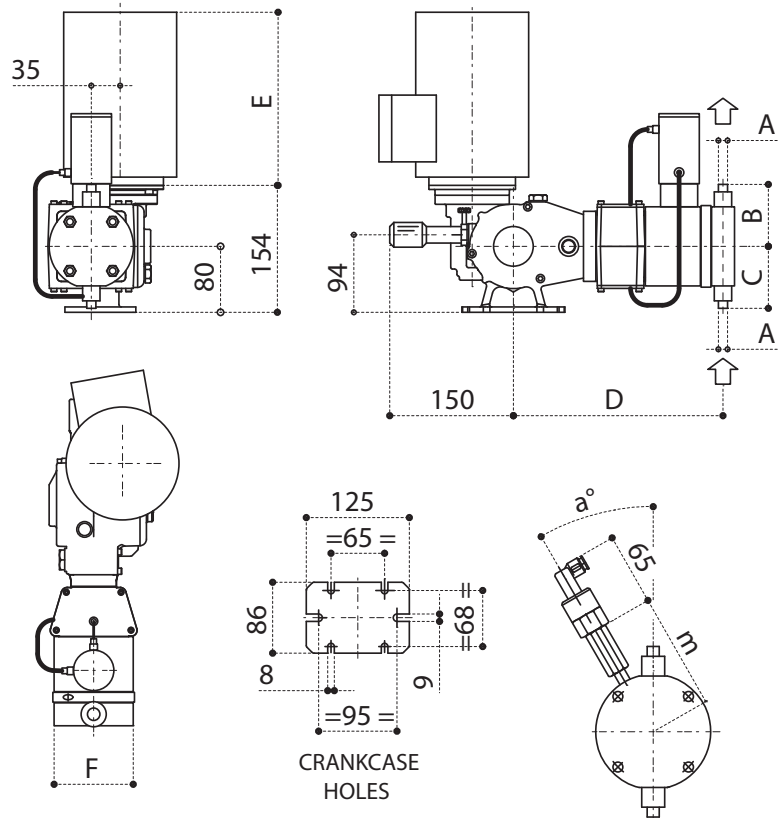

STANDARD DETECTION LOCAL VISUAL

Pump Head Materials	standard		specials		
	21	55	35	45	61
Pump head	SS 316 L	PP	PVC	PVDF	ALLOY 20
Process Diaphragm	PTFE	PTFE	PTFE	PTFE	PTFE
Valves	SS 316L	CERAMIC	CERAMIC	CERAMIC	CERAMIC
Valve Seats	SS 316L	PTFE	PTFE	PTFE	ALLOY 20

### Model number (Key to symbols)

<b>W</b>	Pump Type
<b>S1</b>	Mechanism Type
<b>F</b>	Stroke Length (F= 10 mm)
<b>047</b>	Piston Diameter
<b>A</b>	Strokes/Minutes (A= 58 • B=78 • C=116)
<b>21</b>	Pump Head Materials (see table)
<b>A4</b>	Motor Power
<b>000</b>	Optional

### Liquid End

SS 316L or PP pump head (standard). The material in contact with the liquid to be dosed are listed in the "pump head materials" table (special materials may be supplied on request)

### Flow Rate Adjustment

Metric accuracy better than 1% through the normal operating range of 10 to 100% of capacity. Every pumps can be equipped standard by manual knob. Automatic capacity control as for 4-20mA, 3-15p.s.i. or inverter on request.

**Max. Suction Height: 2 mt**

# WS2 Exacta Series

## Hydraulic sandwich diaphragm metering pumps

Cast iron body available: **WH2**  
motor power (K4) 0.55 kW

### Technical Features

Flow Rate	from 1,5 to 500 lt/h (0,4 to 132,3 gph)	
Pressure Max.	<b>SS 316L Version</b>	80 bar (1160 psi)
	<b>PP Version</b>	10 bar (145 psi)
Stroke rate	58 • 78 • 116 stokes/minutes	
Piston Ø	from 6 to 86 mm	
Motor Powers	Standard 0,25 • 0,37 kW (IP55)	
Stroke Length	20 mm	

### Model number (Key to symbols)

<b>W</b>	Pump Type
<b>S2</b>	Mechanism Type
<b>G</b>	Stroke Length ( <b>G= 20 mm</b> )
<b>086</b>	Piston Diameter
<b>A</b>	Strokes/Minutes ( <b>A= 58 • B=78 • C=116</b> )
<b>21</b>	Pump Head Materials (see table)
<b>C4</b>	Motor Power
<b>000</b>	Optional

### WS2 Exacta Series

Model	Piston Ø	Stroke Length	50 Hz						60 Hz				Max. Pressure				Electric Motor	Suc/Dis. Connec.	
			Strokes /min.	Max. Flow Rate		Strokes /min.	Max. Flow Rate		SS 316L		PP		kW	SS 316L	PP				
				lt/h	gph		lt/h	gph	bar	p.s.i.	bar	p.s.i.							
																Ø BSP			
mm	mm	mm	mm	mm	mm	mm	mm	mm	mm	mm	mm	mm	mm	mm	mm	mm			
W S2 G 006 A	6	20	58	1,5	0,4	70	1,8	0,5	80	1160	10	145	0,25	1/4" M	3/8" M				
W S2 G 006 B			78	2,0	0,5	94	2,4	0,6											
W S2 G 006 C			116	2,8	0,7	139	3,4	0,9											
W S2 G 008 A	8	20	58	3,0	0,8	70	3,6	1,0	80	1160	10	145	0,25	1/4" M	3/8" M				
W S2 G 008 B			78	4,0	1,1	94	4,8	1,3											
W S2 G 008 C			116	5,7	1,5	139	6,8	1,8											
W S2 G 012 A	12	20	58	7,0	1,9	70	8,4	2,2	80	1160	10	145	0,25	1/4" M	3/8" M				
W S2 G 012 B			78	10,0	2,6	94	12,0	3,2											
W S2 G 012 C			116	14,0	3,7	139	16,8	4,4											
W S2 G 015 A	15	20	58	10,0	2,6	70	12,0	3,2	80	1160	10	145	0,25	1/4" M	3/8" M				
W S2 G 015 B			78	15,0	4,0	94	18,0	4,8											
W S2 G 015 C			116	20,0	5,3	139	24,0	6,3											
W S2 G 025 A	25	20	58	30,0	7,9	70	36,0	9,5	71	1029,5	10	145	0,37	1/4" F	1/2" F				
W S2 G 025 B			78	41,0	10,8	94	49,2	13,0	71	1029,5			0,25						
W S2 G 025 C			116	60,0	15,9	139	72,0	19,0	55	797,5			0,25 (PP)						
W S2 G 035 A	35	20	58	60,0	15,9	70	72,0	19,0	36	522	10	145	0,37	1/2" F	1/2" F				
W S2 G 035 B			78	80,0	21,2	94	96,0	25,4	36	522			0,25						
W S2 G 035 C			116	120,0	31,7	139	144,0	38,1	28	406			0,25 (PP)						
W S2 G 051 A	51	20	58	130,0	34,4	70	156,0	41,3	17	246,5	10	145	0,37	1/2" F	1/2" F				
W S2 G 051 B			78	172,0	45,5	94	206,4	54,6					0,25 (PP)						
W S2 G 070 A	70	20	58	245,0	64,8	70	294,0	77,8	9	130,5	9	130,5	0,37	3/4" F	1/2" F				
W S2 G 070 B			78	330,0	87,3	94	396,0	104,8											
W S2 G 086 A	86	20	58	370,0	64,8	70	444,0	117,5	6	87	6	87	0,37	1" F	1" F				
W S2 G 086 B			78	500,0	87,3	94	600,0	158,7											

Piston Ø [mm]	Connec. [BSP]	SS 316L Dimension [mm]						
		A	B	C	D	E	F	m
6	1/4" M (DV)	108	109	309,5	Height depends on motor type	Ø99	100	20°
8	1/4" M (DV)	108	109	309,5		Ø99	100	20°
12	1/4" M (DV)	109	110	309,5		Ø99	101	20°
15	1/4" M (DV)	120	119	310		Ø119	111	20°
25	1/4" F (SV)	133	138	323,5		Ø128	115	23°
35	1/2" F (SV)	116	121	332		Ø128	115	23°
51	1/2" F (SV)	125	130	338		Ø149	125	40°
70	3/4" F (SV)	144	149	346,5		Ø175	138,5	32°
86	1" F (SV)	183	189	405	Ø220	161	30°	

Piston Ø [mm]	Connec. [BSP]	PP Dimension [mm]						
		A	B	C	D	E	F	m
6	3/8" M (DV)	108	109	309,5	Height depends on motor type	Ø99	100	20°
8	1/4" M (DV)	108	109	309,5		Ø99	100	20°
12	1/4" M (DV)	109	110	309,5		Ø99	101	20°
15	3/8" M (DV)	120	119	310		Ø119	111	20°
25	1/2" F (SV)	133	138	323,5		Ø128	115	23°
35	3/2" F (SV)	116	121	332		Ø128	115	23°
51	1/2" F (SV)	125	130	338		Ø149	125	40°
70	1/2" F (SV)	144	149	346,5		Ø175	138,5	32°
86	1" F (SV)	183	189	405	Ø220	161	30°	

SV - Single check valves

DV - Double check valves

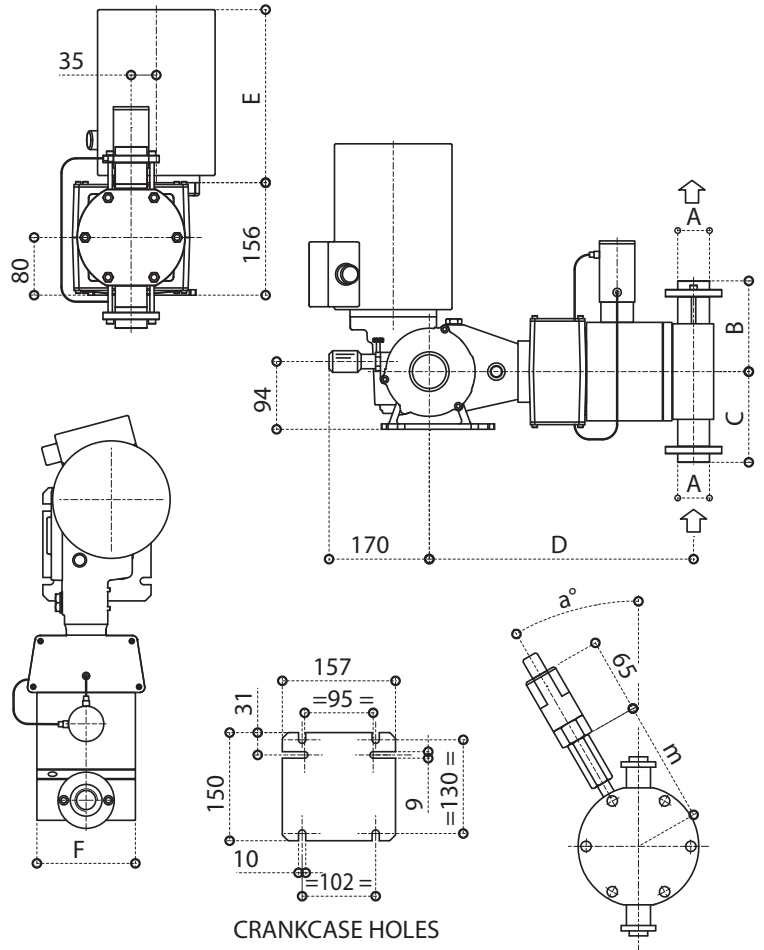

CRANKCASE HOLES

STANDARD DETECTION LOCAL VISUAL

#### Liquid End

SS 316L or PP pump head (standard). The material in contact with the liquid to be dosed are listed in the "pump head materials" table (special materials may be supplied on request)

#### Flow Rate Adjustment

Metering accuracy better than 1% through the normal operating range of 10 to 100% of capacity. Every pumps can be equipped standard by manual knob. Automatic capacity control as for 4-20mA, 3-15p.s.i. or inverter on request.

**Max. Suction Height: 2 mt**

Pump Head Materials	standard		specials		
	21	55	35	45	61
Pump head	SS 316 L	PP	PVC	PVDF	ALLOY 20
Process Diaphragm	PTFE	PTFE	PTFE	PTFE	PTFE
Valves	SS 316L	CERAMIC	CERAMIC	CERAMIC	CERAMIC
Valve Seats	SS 316L	PTFE	PTFE	PTFE	ALLOY 20



SEKO Asia Pacific **SINGAPORE** • SEKO China **CHINA** • SEKO do Brasil **BRAZIL** • SEKO Dosing Systems **USA** • SEKO Deutschland **GERMANY** • SEKO France **FRANCE** • SEKO Iberica **SPAIN** • SEKO Italia **ITALY** • OOO SEKO **RUSSIA** • SEKO Northern Europe **DENMARK** • SEKO SIETA **ROMANIA** • SEKO Southern Africa **SOUTH AFRICA** • SEKO UK **UNITED KINGDOM**

[www.seko.com](http://www.seko.com)